

# GRADALL®

## D172

### HYDRAULIC EXCAVATOR



D172 HIGHWAY SPEED HYDRAULIC EXCAVATOR

## SPECIFICATIONS

### Engine

- Cummins ISB 6.7. 660 ft lb Torque @ 1600 rpm. 300 hp @ 2600 rpm

**Intake:** Electric grid air warmer

#### Air Filter

- 2-stage dry type with safety element, ejector valve and service indicator

#### Electrical System

- 12 volt, 160 amp alternator with integral voltage regulator. 2 SAE Group 31 1900 CCA batteries

**Fuel Tank Capacity:** 80 gal (303 L)

**DEF Tank Capacity:** 13 gal (49 L)

**Gear Speeds** (with 11R22.5 tires)

Gear	1	2	3	4	5	REV
MPH	10.6	21.7	31.6	48.7	60	9.74
Km/hr	(17.0)	(34.9)	(50.9)	(78.4)	(97)	(15.2)

### Upperstructure Cab

- All-weather cab isolated from frame on rubber mounts
- Tinted safety glass windows
- Skylight
- Acoustical lining
- Four-way adjustable seat
- Dome light
- Filtered air heater and defroster
- Air conditioning
- AM/FM radio
- Heat source is provided by a fast response, closed circuit hydraulic heater with 20,000 BTU/Hr. capacity
- Front window slides to overhead storage
- Rearview mirrors on right and left sides of the machine
- Windshield wiper and washer
- Operator's seat belt

### Upperstructure Controls

- Two electronic joysticks control (hoist, bucket, telescope and swing)
- One rocker switch (tilt) control
- Joysticks are mounted on arm pods that are adjustable for individual operator comfort and convenience
- Quick change joystick pattern using interactive display
- Two foot pedals for remote control of undercarriage travel and brakes
- Steering is handled with a rocker switch on top of the left hand joystick
- Forward and reverse travel selected with right-hand joystick button
- Self-centering joysticks and pedals; when controls are released, power for movement disengages and swing and travel brakes set automatically

#### System Monitor

- Top selector buttons include
  - Joystick pattern, hour meter and indicator lamps
- Bottom selector buttons include
  - Engine speed control, auto idle select
  - A/C on select and heater temperature control

#### The display shows as follows

- Park brake
- Low air brake pressure
- Malfunction indicator lamp (mil)
- Hydraulic oil level warning
- Hydraulic oil filter warning
- Engine stop lamp
- Amber warning lamp (engine)
- Wait to start lamp
- Diesel particulate filter lamp
- High exhaust system temperature
- Engine speed
- Fuel level
- DEF level
- Transmission gear request
- Transmission gear status
- Transmission oil temp
- Hydraulic oil temp
- Mode status (travel/remote)
- Check transmission lamp
- Cab blower fan

### Boom

- Two piece triangular telescoping boom
- Adjustable boom rollers with eccentric shafts
- 220° boom tilt
- 90° boom pivot angle

### Hydraulic System

#### Pumps

- One load-sensing bent axis piston pump; 0-58 GPM (0-219 L/min) total

#### SYSTEM SPECIFICATIONS

##### Four Double Acting Cylinders

- 2 hoist cylinders: 3.25" bore x 2.25" rod x 28.5" stroke (83 mm x 57 mm x 724 mm)
- 1 tool cylinder: 4.5" bore x 2.5" rod x 18.88" stroke (114 mm x 63.5 mm x 479 mm)
- 1 boom cylinder: 3.25" bore x 2.25" rod x 123" stroke (83 mm x 57 mm x 3124 mm)

##### Two Hydraulic Motors

- Swing, 51 hp (38kW); Tilt, 21 hp (16kW)

##### Operating Pressures

- Hoist..... 3,800 psi (262 BAR)
- Tilt ..... 2,500 psi (172 BAR)
- Swing ..... 3,800 psi (262 BAR)
- Tool ..... 3,800 psi (262 BAR)
- Telescope ..... 3,800 psi (262 BAR)
- Pilot system..... 550 psi (38 BAR)

##### Oil Capacity

- Reservoir 62 gallons (235 L)
- System 68 gallons (257 L)
- Pressurized reservoir with visual oil level gauge

##### Filtration System

- 5 micron return filter
- 10 micron pilot filter
- Fin and tube-type oil cooler with thermostatically controlled cooling fan
- Pressure-compensated, load-sensing valves with circuit reliefs in all circuits

## Undercarriage

- 4 x 2
- Wheelbase: 190" (4.83 m)
- Width 102" (2.6 m)

### Transmission

- Allison 3500 RDS automatic

### Gross Vehicle Axle Weight Rating

- 37,320 lb (16,928 kg)

### Front Axle

- 14,320 lb (6495 kg) rating

### Rear Axle

- 23,000 lb (10,433 kg) rating 6.43 ratio
- Single reduction with driver controlled differential lock.

### Suspension

- Front: leaf springs with automatic lock-out cylinders
- Rear: solid mount

### Brakes

- Front: Meritor "Q+" Series
  - Cam-Master Size: 16.5" x 5" (419 mm x 127 mm)
  - ABS Brakes
  - Automatic slack adjusters.
- Rear: Meritor "Q+" Series
  - Cam-Master Size: 16.5" x 7" (419 mm x 178 mm)
  - Automatic Slack Adjusters.
- Spring brake system incorporates emergency and parking brakes on the rear axle

### Wheels

- Hub piloted disc 10-stud
- 11.25" (286 mm) bolt circle

### Tires

- Front: 275/80R22.5 16-ply highway traction tread
- Rear: M/S11R22.5 14-ply mud and snow traction tread

### Steering

- Integral hydraulic power steering

### Standard Chassis Equipment

- Halogen headlights
- Tail lights
- Back-up lights and alarm
- Stoplights
- Identification lights front and rear
- Directional lights
- Four-way hazard lights
- Front tow hooks
- Desiccant type air dryer with automatic purge valve

## Chassis Cab

- Two-person cab
- Sun visor
- Gauges:
  - Oil pressure
  - Coolant temperatures
  - Air tank pressures
  - Fuel level
  - DEF level
  - Voltmeter
  - Speedometer with odometer
  - Tachometer
  - Hour meter
- Engine and transmission monitor lights
- Engine shutdown controlled by engine electronics
- Indicator lights and controls for rear axle differential lock
- Park brake control
- Tinted safety glass
- Roll up and down windows
- Instrument panel lights
- Windshield wiper/washer
- West coast style mirror system with plane and convex mirrors

- Fresh air heater and defroster
- Thermostatically controlled heater
- Dome light
- Air suspension seat with seat belt both driver and passenger
- Key ignition switch with neutral start
- AM/FM bluetooth radio
- Dual electric horns
- Center storage console
- 12 volt power supply in dash
- Aluminum kick plates on insides of both chassis doors

## Swing

- Priority swing circuit with axial piston motor
- Planetary transmission

**Swing speed:** 8 rpm

### Swing Brake

- Automatic spring-set/hydraulic release wet-disc swing brake
- Dynamic braking is provided by the hydraulic system

## Hydraulic Remote Control

- Upperstructure powered by chassis hydraulics through PTO
- Travel and brake pedals in the upperstructure cab
- Steering controlled with rocker switch on left-hand joystick
- Digging brakes and front axle lockout cylinders set automatically with travel pedal in neutral
- Parking brakes controlled by toggle
- Electrically operated alarm mounted on undercarriage signal remote control movement in either direction, reverse movement when driven from undercarriage cab

## GRADALL Model D172 4x2 Lift Capacity Over Side or Rear - LB. (kg)

LOAD POINT HEIGHT		LOAD RADIUS					
		15' 0" (4.6 m)		20' 0" (6.1 m)		Maximum radius	
		Over End	Over Side	Over End	Over Side	Over End	Over Side
ABOVE GROUND LEVEL	19' 1" (5.8 m)					3000 (1360)	3000 (1360)
	15' 0" (4.6 m)	4660 (2115)	4660 (2115)	3180 (1440)	3180 (1440)	2880 (1305)	2880 (1305)
	10' 0" (3.0 m)	5390 (2445)	5390 (2445)	3530 (1600)	3530 (1600)	2880 (1305)	2880 (1305)
	BOOM LEVEL 8' 8" (2.7 m)	5490 (2490)	5490 (2490)	3580 (1625)	3580 (1625)	2885 (1310)	2885 (1310)
	5' 0" (1.5 m)	5480 (2485)	5480 (2485)	3615 (1640)	3615 (1640)	2905 (1320)	2905 (1320)
AT GROUND LEVEL		4760 (2160)	4760 (2160)	3365 (1525)	3365 (1525)	2950 (1340)	2950 (1340)
BELOW GROUND LEVEL	5' 0" (1.5 m)	3690 (1675)	3690 (1675)			2955 (1340)	2955 (1340)
	10' 0" (3.0 m)	2695 (1220)	2695 (1220)			2690 (1220)	2690 (1220)
	10' 9" (3.3 m)					2580 (1170)	2580 (1170)

**NOTE:** The above loads are in compliance with the SAE standard J1097 DEC2005. They do not exceed 87% of hydraulic lifting capacity or 75% of tipping capacity.

The rated lift capacity is based on the machine being equipped with 4,500 lb (2041 kg) counterweight, standard boom, standard tires, no auxiliary hydraulics and no bucket.

The load point is located on the bucket pivot point, including load listed for maximum radius.

Do not attempt to lift or hold any load greater than these rated values at specified load radii and heights. The weight of slings and any auxiliary devices must be deducted from the rated load to determine the net load that may be lifted.

**ATTENTION:** All rated loads are based on the machine being stationary and level on a firm supporting surface. For safe working loads, the user must make allowance for his particular job conditions such as soft or uneven ground, out of level conditions, side loads, hazardous conditions, experience of personnel, etc. The operator and other personnel must fully acquaint themselves with the Operator's Manual furnished by the manufacturer before operating this machine. Rules for safe operation of equipment must be adhered to at all times.

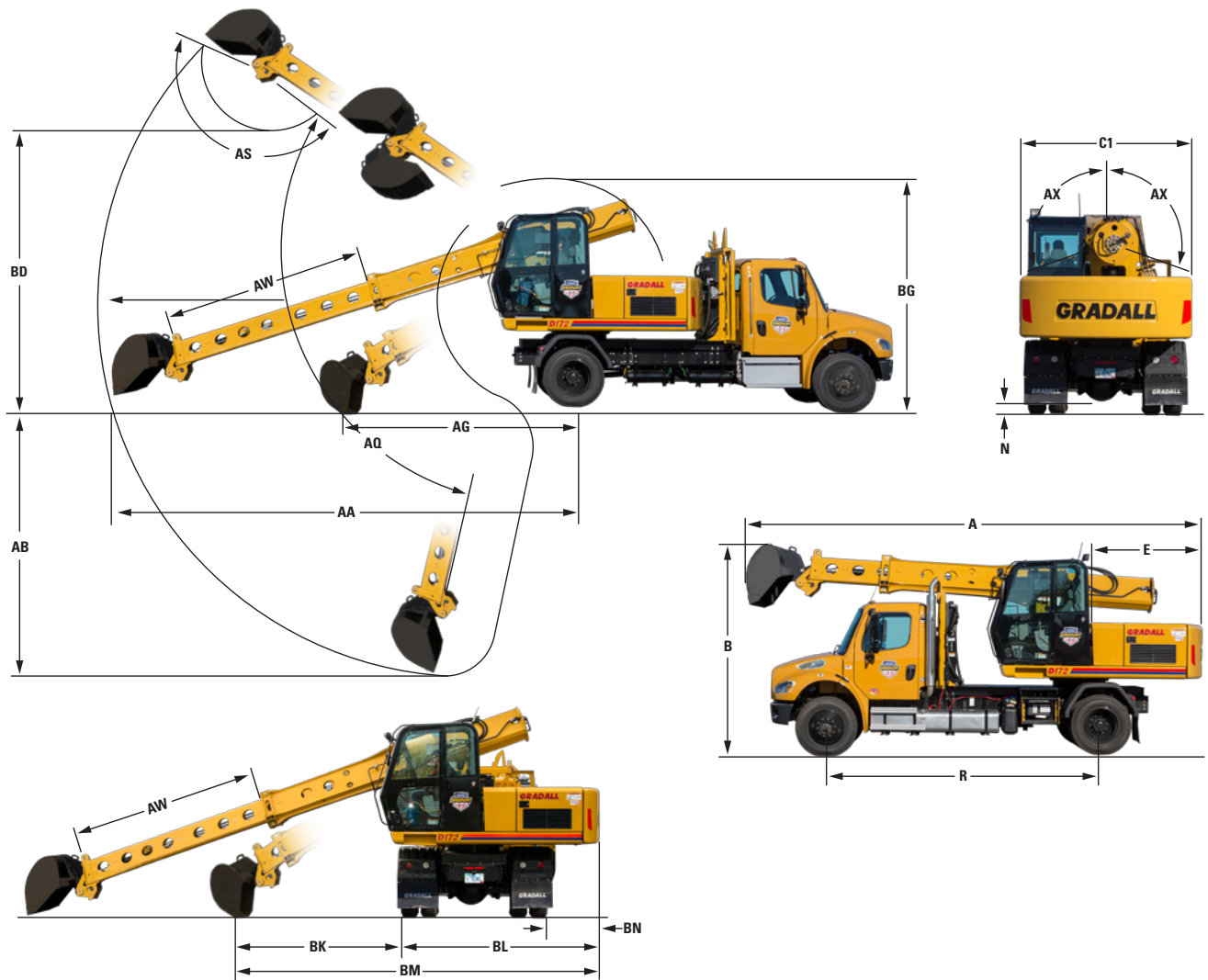

## Dimensions

### 4 x 2

<b>A</b>	27'1" (8.3 m)	Overall length (boom in rack) with bucket
<b>B</b>	12'3" (3.7 m)	Overall height (boom in rack) with bucket
<b>C1</b>	8'6" (2.6 m)	Width of upperstructure
<b>E</b>	6'7" (2.0 m)	Swing clearance, rear of upperstructure
<b>N</b>	10" (254 mm)	Ground clearance (per SAE J1234)
<b>R</b>	15'10" (4.8 m)	Wheelbase
<b>AA</b>	24'11" (7.6 m)	Maximum radius at ground line (165° pivot)
<b>AB</b>	13'6" (4.1 m)	Maximum digging depth (165° pivot)
<b>AG</b>	11'4" (3.5 m)	Minimum level cut radius with bucket flat on ground line
<b>AQ</b>	30° Up & 60° Down	Boom pivot angle

### 4 x 2

<b>AS</b>	165°	Bucket pivot angle
<b>AW</b>	10'3" (3.1 m)	Telescoping boom travel
<b>AX</b>	110°	Bucket tilt angle (both sides of center)
<b>BD</b>	16'4" (5.0 m)	Minimum clearance of bucket teeth, with bucket pivot at maximum height
<b>BG</b>	14'1" (4.3 m)	Maximum height of working equipment with bucket below ground line
<b>BK</b>	6'8" (2.0 m)	Minimum bucket cleanup
<b>BL</b>	10'8" (3.3 m)	Swing lane clearance
<b>BM</b>	17'11" (5.5 m)	Minimum machine swing radius at ground level
<b>BN</b>	30" (762 mm)	Passenger side swing clearance

## Function Forces

### Rated boom force:

16,387 lb (72.9 kN)

### Rated bucket breakout force:

11,400 lb (50.7 kN)

## Weight

- Approximate working weight, including a 60" (1.54 m) bucket, fuel tank half full
- 4 x 2: 32,200 lb (14,600 kg)

## Optional Equipment

- Set of five working lights
- Passenger side door step
- Auxiliary hydraulics
- Rear step

## Attachments

- Buckets fabricated of steel plate, with high strength, low alloy cutting edges and wear strips
- Standard attachments available for wide range of applications

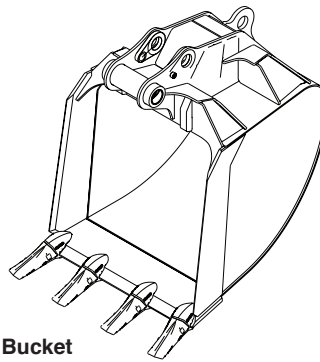

**Excavating Bucket**

8215-6008	36" (914 mm)	yd <sup>3</sup> 5/8	m <sup>3</sup> 0.54
	785 lbs (356 kg)		

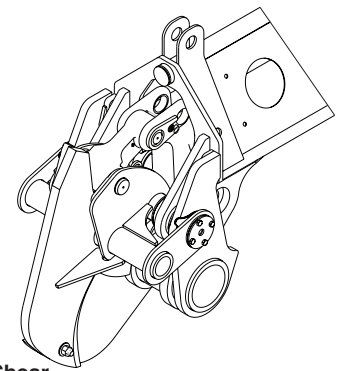

**Tree Limb Shear**

8215-5004 770 lbs (349 kg)

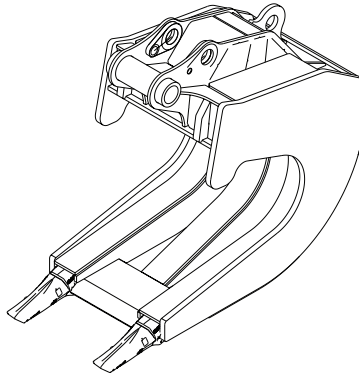

**Pavement Removal Bucket**

8215-6004 24" (0.610 m)  
1284 lbs (582 kg)

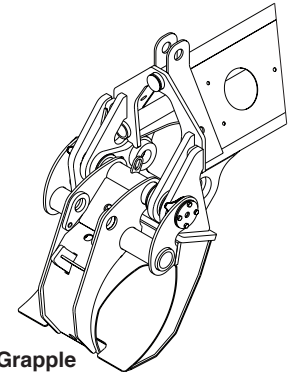

**Fixed Thumb Grapple**

8215-5003 530 lbs (240 kg)

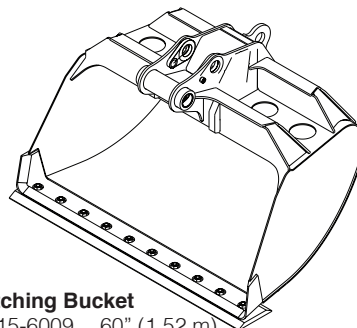

**Ditching Bucket**

8215-6009 60" (1.52 m)  
784 lbs (356 kg)

8215-5001 60" (1.52 m)  
914 lbs (415 kg)

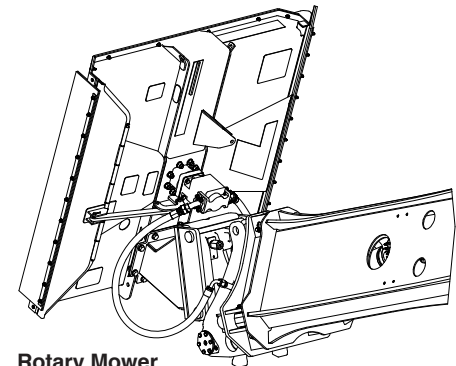

**Rotary Mower**

8215-5005 50" (1.27 m)  
1290 lbs (585 kg)

**Flail Mower**

8215-5006 40" (1.02 m)  
1053 lbs (478 kg)

It is Gradall Policy to continually improve its products. Therefore designs, materials and specifications are subject to change without notice and without incurring any liability on units already sold. Units shown may have optional equipment.

# GRADALL®

406 Mill Ave. SW, New Philadelphia, Ohio 44663  
Phone: 800-445-4752  
www.Gradall.com



Form No. 12201 4/22  
Printed in USA